



markem·imaje

a DOVER company



## Thermal transfer overprinting **SmartDate® OEM Connect**



SmartDate® OEM Connect with the optional Remote User Interface (RUI)

### Seamless integration into your packaging machines

Designed for seamless integration into medium-to-high-duty equipment, the **SmartDate® X45** and **SmartDate® X65** OEM Connect delivers an effortless, cost-effective, trouble-free solution for OEM integration.

The **SmartDate®** OEM Connect has been designed to be easily installed in small footprints and reduced cabinet space. It is compact enough to be connected in any mounting configuration while offering the full capabilities of the **SmartDate® X45** and **SmartDate® X65** for message selection, production monitoring and help tutorials.

With the **SmartDate®** OEM Connect, integration has never been easier.

## Product features

### Seamless integration

- Set up with web browser for easy communication with the host Human Machine Interface (HMI).
- Utilizing the full functionality of the **SmartDate® X45** and **SmartDate® X65** connectivity with WEB User Interface or Virtual Network Computing (VNC)\* via Host HMI.
- An optional touchscreen remote user interface can be connected and positioned anywhere on the packaging machine.

### Operation optimization

- **SmartDate® X45** and **SmartDate® X65** printers adaptable for intermittent or continuous line configuration.
- Can be easily changed from left to right hand with no additional parts.
- Print speed can be set from 10 mm to 1,800 mm\*\* per second allowing for 455 printed packs per minute up to 300 dpi.

### Enhanced user experience

- A range of animated help and “how to” tutorials\* providing guidance on setup and daily maintenance procedures to ensure high print quality directly from the packaging machine HMI.
- Eliminate defective codes with seamless connectivity to Detect-Plus, **CoLOS®** Mark & Read and other **CoLOS®** solutions.
- 24/7 help desk support and extensive network of on-site technical support. Advanced Exchange Service\*\*\* for a quick response and delivery of spare parts available in most geographic locations.

\*Virtual Network Computing does not support video playback.  
\*\* SmartDate® X65 \*\*\* See conditions defined by Markem-Imaje.

# SmartDate® OEM Connect Specifications

## Print Features

### Print speed:

Intermittent: up to 700 mm/s  
Continuous: 10 to 1800 mm/s

### Print area:

Intermittent: 32 mm, 53 mm or 128 mm x 75 mm  
Continuous: 32 mm, 53 mm or 128 mm x 250 mm  
Extended length available, contact Markem-Imaje

### Gap between prints: 0.5 mm

### Print features:

Automatic printhead setup  
Detect: Dead-dot detection  
Quick change printhead  
Combined intermittent and continuous printer  
Easily change from left to right hand with no additional parts  
Automatic shift codes and serial numbers  
Multiple variable user input fields with alpha-numeric texts  
High-pack rate mode

**Print features:** Printing of real-time clock, dates and auto-updating best before dates, barcodes

**Fonts:** True Type font support, including non-Roman characters and symbols

**Wide choice of 1D and 2D barcodes:** ITF, Code 39, Code 128, EAN 128, EAN 8, EAN 13, UPC A, UPC E, RSS linear, PDF 417, GS1 standard compliant, Data Matrix, QR and Composite RSS barcodes support

## Consumable Specifications

Thermal transfer ribbons available in a variety of grades and colors

**Maximum ribbon length:** up to 1100 m

**Minimum ribbon width:** 20 mm

**Maximum ribbon width:** 130 mm

**Ribbon save options:** Radial ribbon save mode, interlaced mode, whitespace mode and negative ribbon advance

Best results with **SmartDate® Xceed**, **SmartDate® Xtra** and **SmartDate® Xpert** ribbon ranges

## Operating Characteristics

WEB User Interface or Virtual Network Computing, enables full functionality of the **SmartDate®** printer directly from the HMI (Human Machine Interface) of the packaging machine

**SmartDate® X45** and **SmartDate® X65** user familiarity: Animated help tutorials, print/image adjust, on-board configurable password protection

WYSIWYG print preview of the printed message, real-time display of remaining prints expressed in hours and number of prints

**Line analysis:** a built-in process improvement tool. Once enabled, packaging line downtime reasons can be logged and analyzed, facilitating data-driven decision-making

Suite of diagnostics tools available

**Message storage:** Can be stored directly on the controller, on the USB, or on the network

### Hardware interface:

Inputs: "Print go" and 1 configurable input  
Outputs: Fault, warning, and 2 configurable outputs

### Software interface:

USB for downloading images, settings and data files. RS232, Ethernet communications standard

**Communication protocol:** via the Web Browser on the host PC, via enhanced DCP Communications and via NGPCL Protocol.

Parent/Child function to allow control up to 7 printers

## Weight:

- Printer: 7.8 kg
- SmartDate® X45** and **SmartDate® X65** OEM Connect: 3 Kg
- Optional RUI: 2.63 Kg

## Environment:

Temperature range: 0°C to 40°C  
Humidity: 10% to 90% non-condensing  
Electrical power supply:

- SmartDate® X45** OEM Connect - 100-230V AC (+/-10%), 50/60Hz.
- SmartDate® X65** OEM Connect - 115-230V AC (+/- 10%) 50/60Hz.

Air consumption: from 0.4 ml/print at 2.5 bar

Air supply: 6 bar/90 psi (maximum) dry, uncontaminated

Remote user interface IP rating: IP66

## Options and Accessories

Detect-Plus: Code detection

Promotional coding

Mounting bracket, encoders, and barcode scanner

Remote User Interface

## Service

Markem-Imaje offers the sector's most comprehensive array of digital, remote and on-site services to further empower our customers to maximize the return on their investment in our solutions. Designed to satisfy Industry 4.0 demands for increased customization and remote 24/7 digital assistance to reduce downtime, the portfolio of maintenance services is tailored according to user needs, skills and available resources.

## Software

Included **CoLOS®** Free for design of simple messages.

## SmartDate® OEM Connect

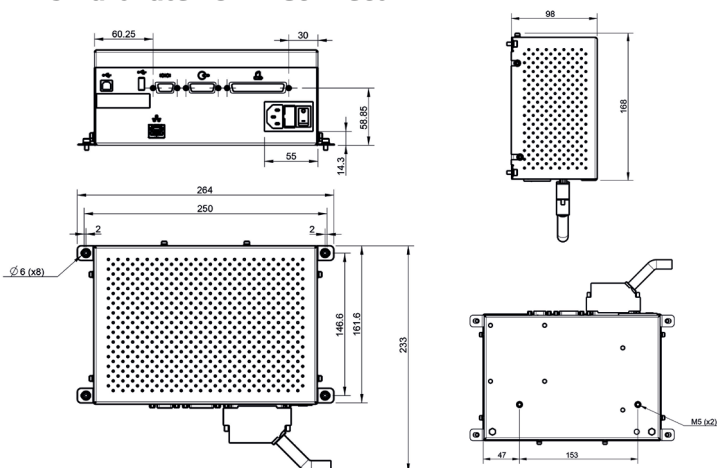

## Optional RUI

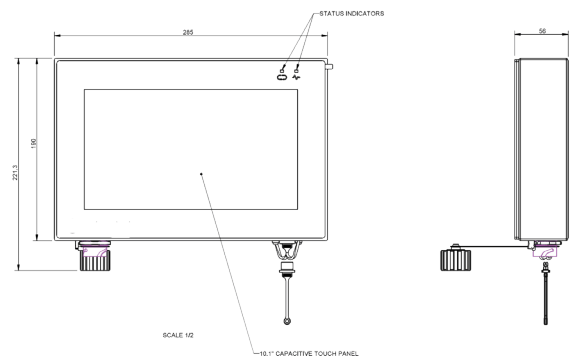

markem·imaje  
a DOVER company